

New GrN Product Release

Polyurethane Nylon Bushes (now legal for Grp N Use)

Application: Lancer Evolution VII/VIII/IX

Homologation: Appendix J Art. 254 Group N for 2010 *“A silent block/bush may be replaced with a new bush of which the shape is free and the maximum hardness is 80 shores –Type A”*

Rubber and polyurethane use the same Shore “A” rating

The **rubber** compound contains natural products which deteriorate with age. It becomes softer and more pliable, resisting the forces placed on it less and less as time goes by. This allows for more movement of the suspension components and offers less control over the suspension geometry.



Polyurethane doesn't contain these properties and therefore doesn't deteriorate in the same way or anywhere near as quick. It is a much more hardy material and is therefore less susceptible to deterioration from competition driving, road salts and fluids like petrol and oil. Also designs can differ. Generally with rubber bushes they are designed as a metal bush would be with an outer and inner sleeve. This allows for twisting of the bush and greater friction, which can lead to tearing of the rubber as the steel sleeves shift under load around the rubber.

(See attached list of available Polyurethane bushings for Evo 7/8/9)

REINFORCED BUSHING / MOUNTING DIAGRAM
(CT9A - EVO7/8/9)

(TPFF44-105) INSULATOR, E/G & T/M MOUNT

(TPFF44-108)
INSULATOR,
E/G ROLL (REAR)

INSULATOR,
FRONT STRUT
(TRA403282K1)

PILLOW BUSHING,
FRONT LOWER ARM
(REAR)(TRA519675K1)

BUSHING, FRONT
STABILIZER BAR (φ24)
(TPF44-201-24)
(TPF44-201-26)
(TPF44-201-29)

BUSHING, FRONT LOWER
ARM (FRONT)(TPFF44-1011-14)

(TPFR44-111)
REAR CAMBER (INNER)

INSULATOR, E/G ROLL (FRONT)(TPFF44-106)

BUSHING, REAR LOWER ARM
(SHOCK MOUNT)(TRA244851K1)

BUSHING, REAR SHOCK
UPPER (A)

BUSHING, REAR SHOCK
UPPER (B)

PAD, REAR SPRING UPPER

(TPFR44-121)
REAR DIFF BRACKET
MOUNTS

(TPFR44-112)
REAR CAMBER (OUTER)

(TPFR44-109)
BUSHING, REAR UPPER
ARM (BODY SIDE, REAR)

(TRA856461K1)
BUSHING, REAR UPPER
ARM (BODY SIDE, FRONT)

BUSHING, REAR
DIFF SUPPORT ARM
(TPFR44-120)

(TPFR44-115)
REAR TOE ARM

BUSHING, REAR STABILIZER
BAR (φ22) (TPF44-210-22)
(TPF44-210-24)
(TPF44-210-27)

(TPFR44-117) BUSHING, REAR TRAILING ARM

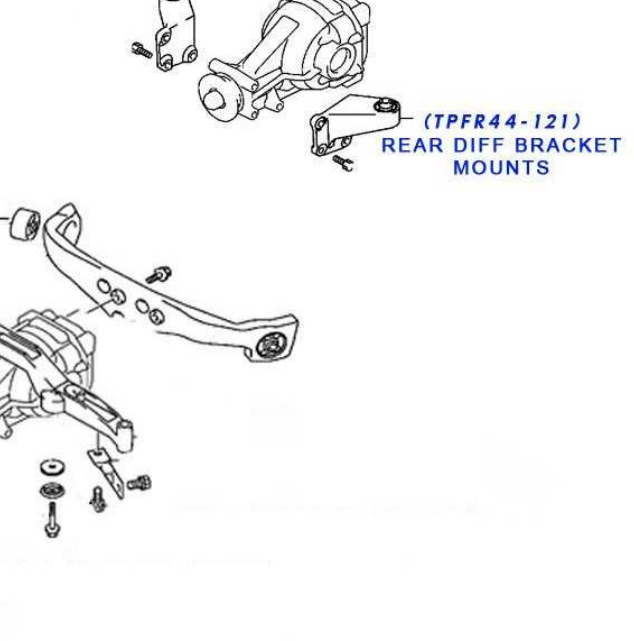
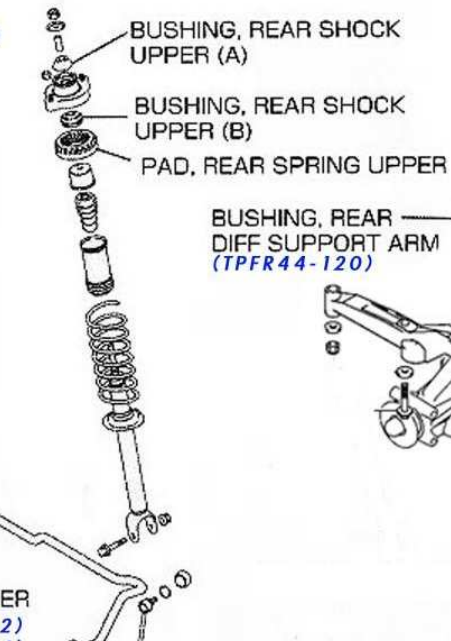
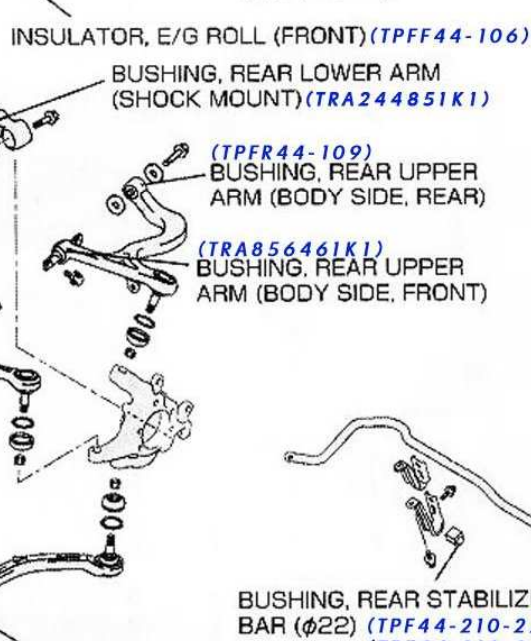
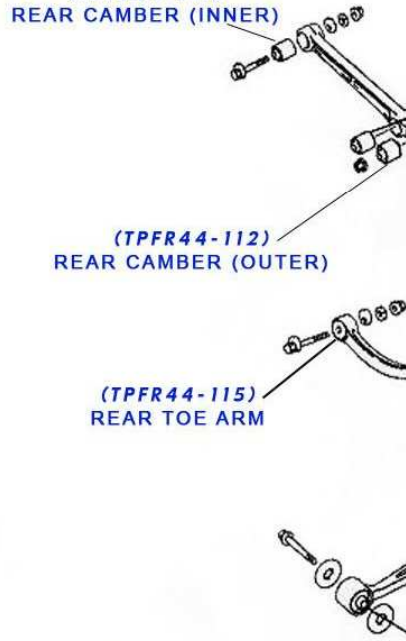
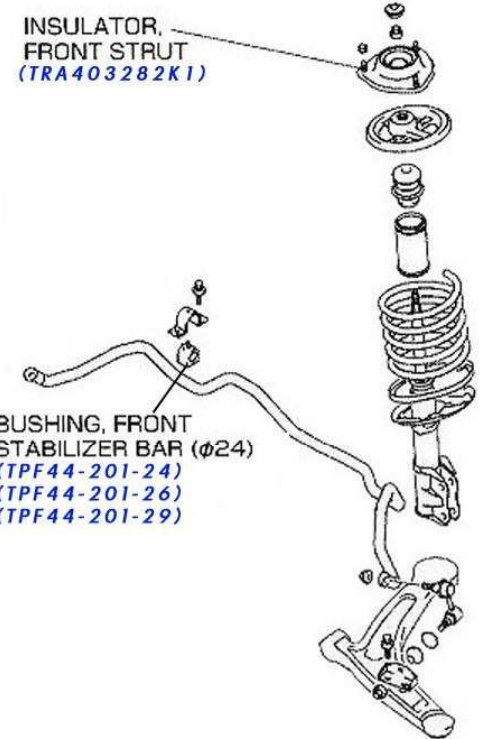
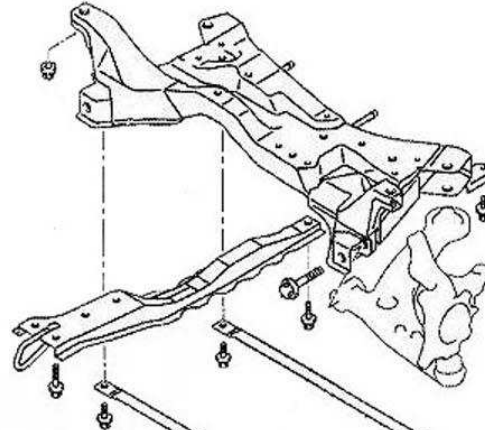
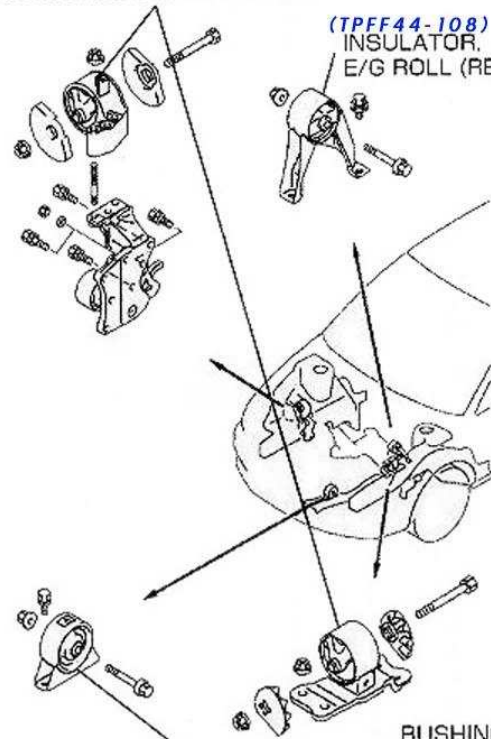

Ralliart UAE Parts Information

Price and reference sheet:

Part Number	Description	Retail Price(AED) EACH	Application
TPFF44-1011-14	FRT WBONE BUSH E789 FRONT	AED 130.00	Evo 7/8/9
TPFF44-201-24	FRT ANTI ROLL BAR BUSH 24MM E789	AED 100.00	Evo 7/8/9
TPFF44-201-26	FRT ANTI ROLL BAR BUSH 26MM E789	AED 100.00	Evo 7/8/9
TPFF44-201-29	FRT ANTI ROLL BAR BUSH 29MM E789	AED 100.00	Evo 7/8/9
TPFF44-105	SIDE ENG & T/M MOUNT CT9A E789	AED 220.00	Evo 7/8/9
TPFF44-106	FRONT LOWER ENG MOUNT E789	AED 190.00	Evo 7/8/9
TPFF44-108	LOWER REAR ENG/DIFF MOUNT 70MM E789	AED 175.00	Evo 7/8/9
TPFR44-109	REAR Y-ARM UPPER BUSH REAR E789	AED 130.00	Evo 7/8/9
TPFR44-111	REAR CAMBER S/ABS ARM BUSH INNER E789	AED 120.00	Evo 7/8/9
TPFR44-112	REAR CAMBER S/ABS ARM BUSH OUTER E789	AED 130.00	Evo 7/8/9
TPFR44-115	REAR TOE ARM BUSH E789	AED 113.00	Evo 7/8/9
TPFR44-117	REAR TRAILING ARMBUSH E789	AED 145.00	Evo 7/8/9
TPF44-210-22	REAR ANTI ROLL BAR BUSH 22MM E789	AED 98.00	Evo 7/8/9
TPF44-210-24	REAR ANTI ROLL BAR BUSH 24MM E789	AED 98.00	Evo 7/8/9
TPF44-210-27	REAR ANTI ROLL BAR BUSH 27MM E789	AED 98.00	Evo 7/8/9
TPFR44-120	REAR DIFF STEEL U XMEMBER BUSH E789	AED 142.00	Evo 7/8/9
TPFR44-121	REAR RS DIFF SIDE MOUNT BUSH E789	AED 135.00	Evo 7/8/9